

BUY OR RENT

Blast Pak Air Dryer System



**Free Initial
Desiccant
Fill**

- **Increase Blasting Profitability**
- **Eliminate Flash Rusting, Clogged Blast Pots and Downtime**
- **Small Footprint**
- **Complete Portability**
- **Low System Pressure Drop**

**Operate With Compressed Air Temperatures
Up to 250°F**

250 through 1600 SCFM Standard Systems

Custom Systems Available

10 Year Vessel Warranty

Product Features

- Steel Skid Forklift Channels and Lifting Lugs for Portability
- Air Motor Includes Filter, Regulator, Lubricator and Muffler
- Epoxy Internal Dryer Coating for Long Vessel Life
- Optional Pneumatic Demand Drain Prevents Air Loss
- Downstream Particulate Filter with Permanent Stainless Steel Mesh
- Two Dryer Sight Windows for Desiccant Level Viewing

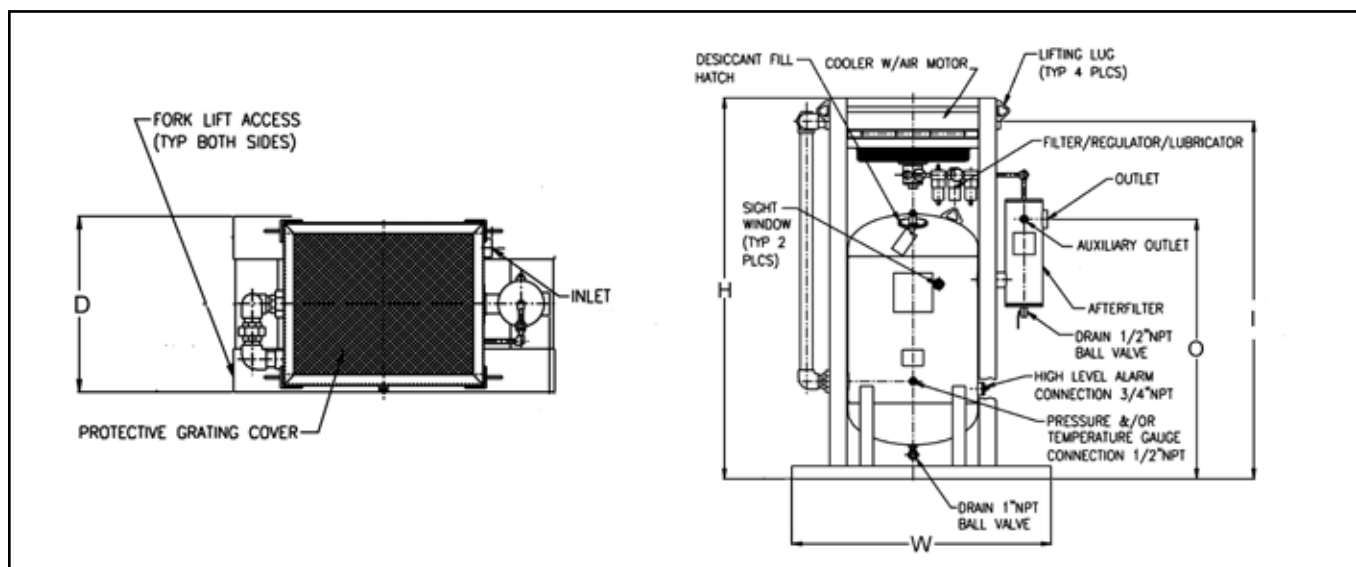

Dimensions	FD-250	FD-400	FD-800	FD-1200	FD-1600
Part Number	80-1456	80-1430	80-1431	80-1416	80-1347
Height	77"	77"	83 - 3/4"	88"	94 - 1/2"
Inlet Height	71 - 9/16"	72 - 1/8"	78 - 3/8"	82 - 5/8"	89 - 3/8"
Depth	27"	26"	32 - 7/8"	32 - 7/8"	43"
Outlet Height	58 - 1/2"	58 - 9/16"	59 - 1/2"	60"	59 - 1/8"
Width	48"	49"	54"	60"	71 - 1/2"
Inlet Size	1-1/2" NPT(F)	2" NPT(F)	2-1/2" NPT(F)	2-1/2" NPT(F)	3" NPT(F)
Outlet Size	1-1/2" NPT(F)	2" NPT(F)	2-1/2" NPT(F)	3" NPT(F)	3" NPT(F)
Weight	660 lbs	760 lbs	1155 lbs	1525 lbs	1875 lbs
Air Motor SCFM	17	25	70	70	150



EAGLE INDUSTRIES

P.O. Box 10652

New Orleans, LA 70181

1.800.266.8246 • www.eagleind.com