



**EAGLE INDUSTRIES**

www.eagleind.com  
800.266.8246

# **BLAST PAK AIR DRYER**

PORTABLE COMPRESSED AIR SYSTEM

## **SPECIFICATIONS**

### **Air Drying Process**



\* **FREE INITIAL DESICCANT FILL**

\* **10 YEAR VESSEL WARRANTY**



**250 CFM    400 CFM    800 CFM    1200 CFM    1600 CFM    (Custom Systems Available)**

- Operates with compressed air temperatures up to 250 ° F
- Steel skid forklift channels and lifting lugs for portability
- Air motor includes filter, regulator, lubricator and muffler
- Epoxy internal dryer coating for long vessel life
- Optional pneumatic demand drain prevents air loss
- Downstream particular filter with permanent stainless steel mesh
- Two dryer sight windows for desiccant level viewing

To the best of our knowledge, these are typical property values & are intended as guides only, not as specification limits. Eagle Industries of Louisiana, Inc. makes no warranties as to the fitness for a specific use or merchantability of products referred to, no guarantee of satisfactory results from reliance upon contained information or recommendations, & disclaims all liability for resulting loss or damage.



**EAGLE INDUSTRIES**

www.eagleind.com  
800.266.8246

# BLAST PAK AIR DRYER

PORTABLE COMPRESSED AIR SYSTEM

## SPECIFICATIONS

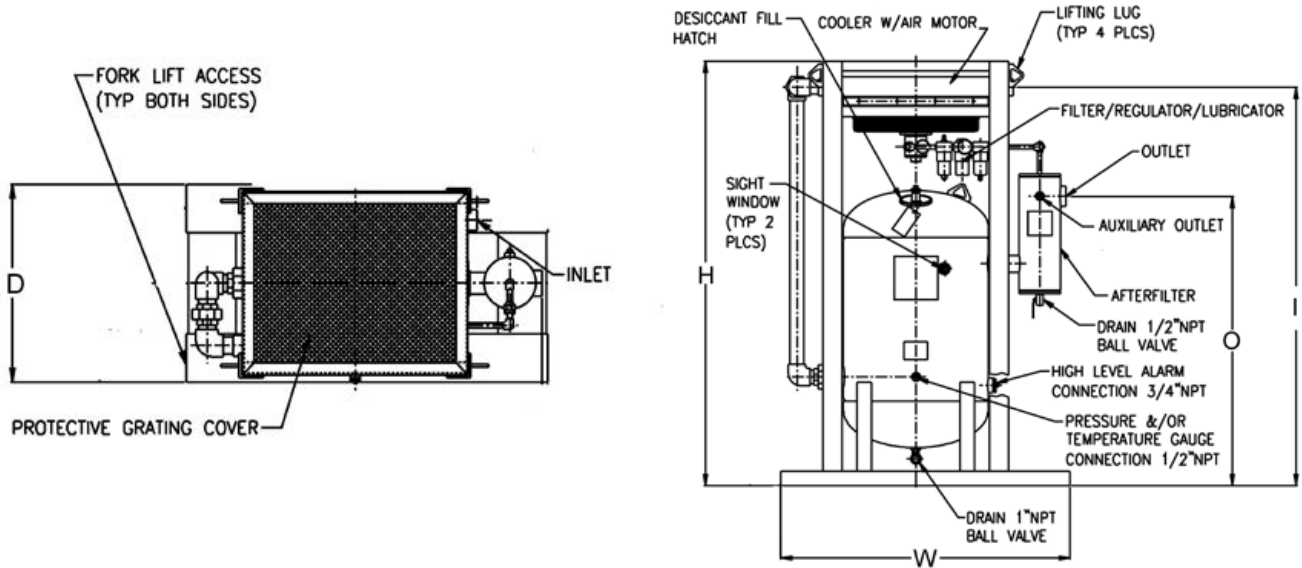

DIMENSIONS	FD-250	FD-400	FD-800	FD-1200	FD-1600
<b>PART NUMBER</b>	80-1456	80-1430	80-1431	80-1416	80-1347
<b>HEIGHT</b>	77"	77"	83 - 3/4"	88"	94 - 1/2"
<b>INLET HEIGHT</b>	71 - 9/16"	72 - 1/8"	78 - 3/8"	82 - 5/8"	89 - 3/8"
<b>DEPTH</b>	27"	26"	32 - 7/8"	32 - 7/8"	43"
<b>OUTLET HEIGHT</b>	58 - 1/2"	58 - 9/16"	59 - 1/2"	60"	59 - 1/8"
<b>WIDTH</b>	48"	49"	54"	60"	71 - 1/2"
<b>INLET SIZE</b>	1-1/2" NPT(F)	2" NPT(F)	2-1/2" NPT(F)	2-1/2" NPT(F)	3" NPT(F)
<b>OUTLET SIZE</b>	1-1/2" NPT(F)	2" NPT(F)	2-1/2" NPT(F)	3" NPT(F)	3" NPT(F)
<b>WEIGHT</b>	660 lbs	760 lbs	1155 lbs	1525 lbs	1875 lbs
<b>AIR MOTOR SCFM</b>	17	25	70	70	150

To the best of our knowledge, these are typical property values & are intended as guides only, not as specification limits. Eagle Industries of Louisiana, Inc. makes no warranties as to the fitness for a specific use or merchantability of products referred to, no guarantee of satisfactory results from reliance upon contained information or recommendations, & disclaims all liability for resulting loss or damage.

5531 River Road, Harahan, LA 70123

**1-800-266-8246**      **www.eagleind.com**

Revised 2015